

01 SECTION  
SCALE 1/50

01 SIDE VIEW  
SCALE 1/50

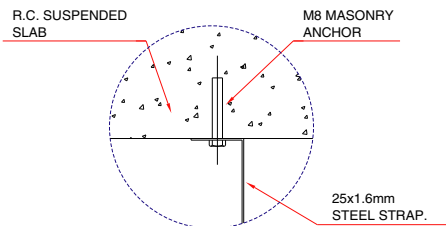

06 DETAIL D  
SCALE 1/5

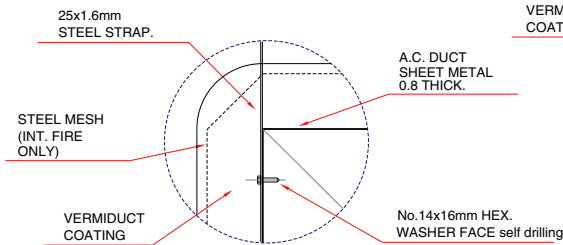

05 DETAIL C  
SCALE 1/5

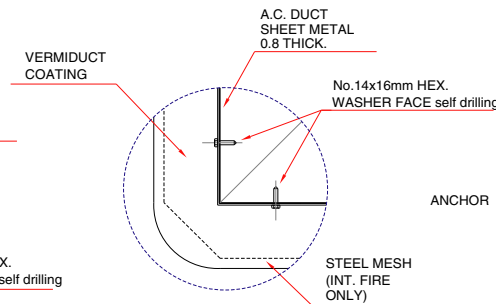

04 DETAIL B  
SCALE 1/5

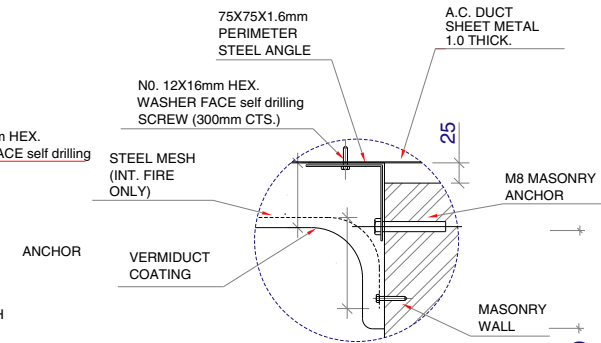

03 DETAIL A  
SCALE 1/5

MINIMUM JOINT TYPE	CENTRES(mm)
25 mm STANDING DRIVE SLIP	2400

DUCTWORK UP TO 600x600mm.

	PRJ.T. A.C. DUCT 600x600mm. - FIRE PROTECTION	JOB N.	AMENDS
	CLIENT L. & A. Fazzini Manufacturing Pty Ltd		
DWG. TITLE SIDE VIEW, SECTION & DETAILS	DATE 17/03/98	DRAWN BY G.A.	
	SCALE	DWG. N. 02	