

02 SECTION
SCALE 1/25

01 SIDE VIEW
SCALE 1/25

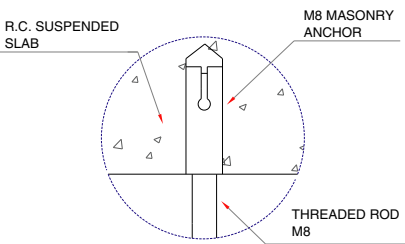

06 DETAIL D
SCALE 1/5

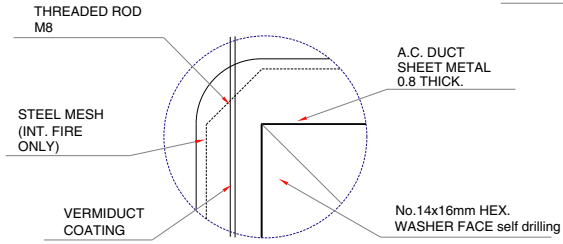

05 DETAIL C
SCALE 1/5

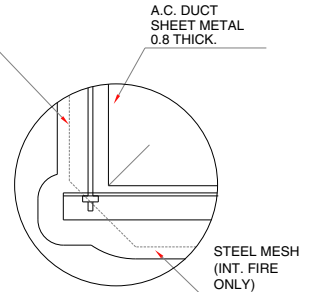

04 DETAIL B
SCALE 1/5

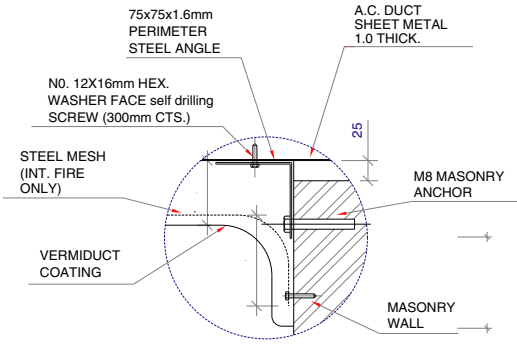

03 DETAIL A
SCALE 1/5

DUCTWORK UP TO 1200x1200mm.

MINIMUM JOINT TYPE	CENTRES(mm)
25 mm STANDING DRIVE SLIP	1520
25mm. MEZ	1520
35mm. TDF	1520

	PRJT. A.C. DUCT 1200x1200mm. - 2HRS. FIRE RATED CLIENT L. & A. Fazzini Manufacturing Pty Ltd	JOB N. AMEND'S
	DWG. TITLE SIDE VIEW, SECTION & DETAILS	DATE 17/03/98 SCALE